



3055 BA SANGAM COLLEGE

PH: 6674003/9264117 E-Mail: basangam@connect.com.fj



WORKSHEET NO: 9

Subject: Applied Technology	Year/Level: 13
Topic : HYDRAULIC PRESS	Date: 26/07/21
Topic: APPLIED ENGINEERING	

The main parts are indicated below:

The tool feed handle can be turned to slowly feed the cutting tool into the material as the 'ram' moves forwards and backwards. The strong machine vice holds the material securely. A small vice would not be suitable as the work could quite easily be pulled out of position and be damaged. The vice rests on a steel table which can be adjusted so that it can be moved up and down and then locked in position. Pulling back on the clutch handle starts the 'ram' moving forwards and backwards

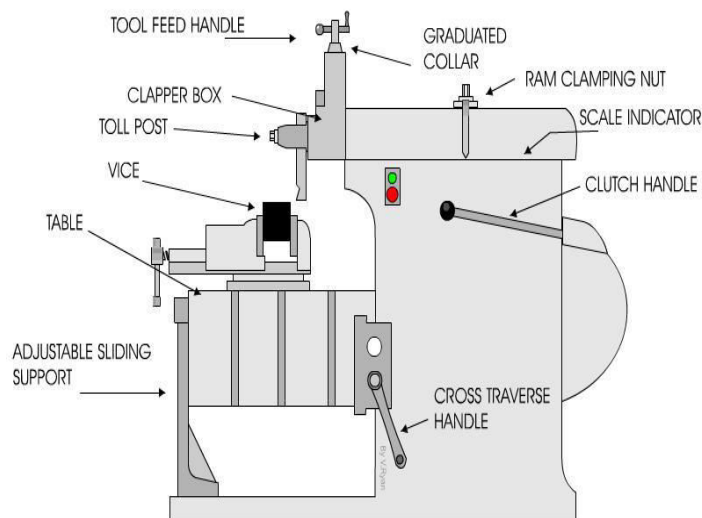



ACTIVITY

1. State the function of Hydraulic Press?

2. Label the missing machine parts

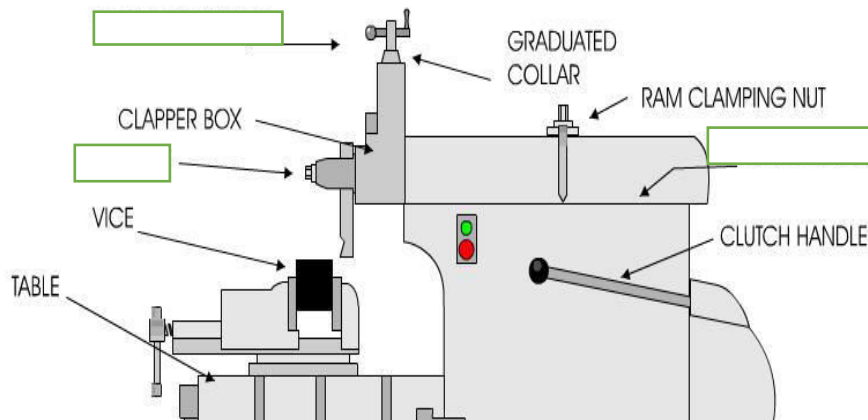

b.