

Strand	BT9.3: DESIGN AND ENTERPRISING
Sub - Strand	BT9.3.2 ENTERPRISING SKILLS
Content Learning Outcome	BT9.3.2 .1 Identify design problems and plan projects; identify types of costs incurred and calculate costs.

ENTERPRISING SKILLS

DOWEL JOINT

Dowel joints can be used for joining two pieces of wood at right angles. Small round pieces of wood called dowel pins are used and saw cuts are made on these to allow any excess glue and air to escape from the holes.

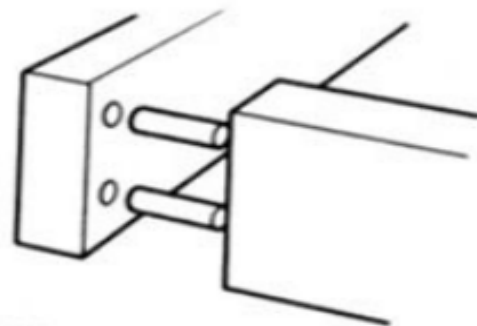

FINISHES

GLOSS PAINTS

Painting my model would give me a range of colours to choose from and would also protect the wood. Paint would be applied in three stages: PRIMER COAT - to seal the grain of the wood; UNDERCOAT - to complete the sealing and cover the grain; GLOSS COAT - to add a shiny finish. Each coat should be brushed on both with and across the grain, and the product should be sanded down between coats.



STAINS

Stains of different colours can be applied to woods. They are applied by cloth or brush change the colour of the wood.

POLYURETHANE VARNISH

Varnish is a clear, hard wearing finish which shows the natural grain of the wood.

INITIAL IDEAS

Are the first steps to creating your design. They should be quick freehand sketches of any ideas that you have.

DEVELOPED IDEAS

Are ideas that build on your initial ideas. Select the best ideas from your previous designs and work on them.

PLANNING FOR MANUFACTURE

This section of the folio should contain all the information that is needed to build your model.

WORKING DRAWING

This should be an orthographic drawing with sizes. This drawing should show all the parts of your design.

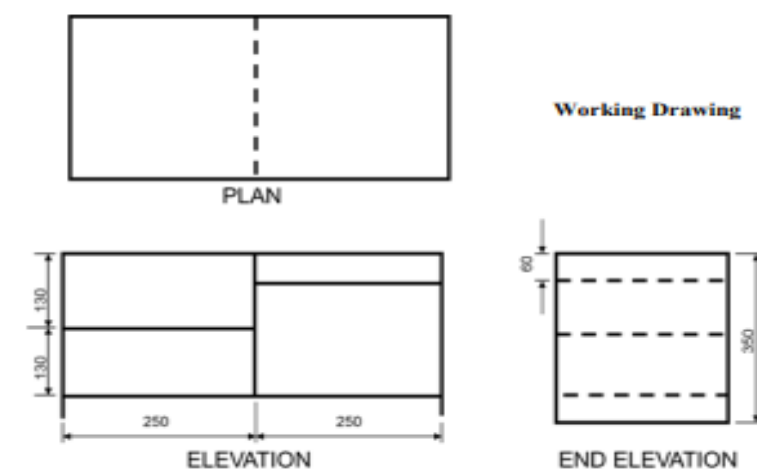

This should be in the form of a table and contain all the different parts, dimensions and materials.

Parts	Dimensions Length x breadth (mm)	Materials	No off
Sides	350x150x12	Plywood	2
Bottom	510x150x12	Plywood	1
Shelves	250x150x12	plywood	2
Partition	280x150x12	Plywood	2
Top	250x165x12	Plywood	1
Back	350x520x3	Hardboard	1

SEQUENCE OF OPERATIONS

This is a detailed list of all the steps needed to make the model. It should cover four main stages: marking out, cutting, drilling and shaping, assembling and then finishing.

PRESENTATION DRAWING

This is a 3- Dimensional drawing of your finished product with colour. It is normally a Perspective, but oblique and Isometric are also acceptable.

WHAT IS EVALUATION?

Is the last part of the folio. It should be done after construction and should check the quality of what has been designed.

SHORT ANSWER QUESTIONS

1. Define the terms:

a) Primer coat:

b) Gloss coat:

c) Undercoat:

2. What is dowel joint?

3. What is cutting list?

4. What should be done after construction and should check the quality of what has been designed.

5. Explain the term sequence of operations?

6. What list is in the form of a table and contain all the different parts, dimensions and materials.

7. Name the joint given below.

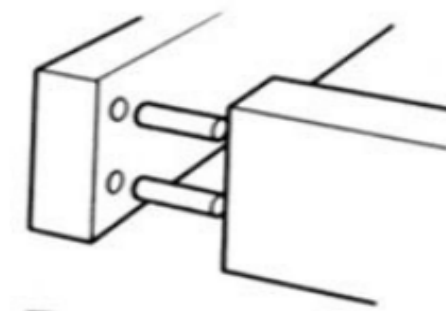

THE END