

PENANG SANGAM HIGH SCHOOL

P.O.BOX 44, RAKIRAKI

WEEK 26 WORKSHEET

Subject: Basic Technology

Year/Level: 10

Strand	BT10.4 HAND TOOLS AND MATERIALS BT10.6 JOINTS AND PROCESSES
Sub Strand	BT10 4.1. HAND TOOLS AND APPLINCES BT10.6.2 METALWORK JOINTS
Content Learning Outcome	BT10.4.1.1 Familiarize with the common woodworking and metalworking hand tools and exhibit competence in their appropriate, safe and effective use. BT10.6.2.1 Identify and state the use of complex metalwork joints and develop confidence in skilful construction of the joints incorporated in tasks, projects and other artefacts.

Give the complete name of the **Parts** marked **X** and **explain** the **use** of the tools.
Name the **parts** labelled **X** given below and **state** the processes.
The first one is already being done for you.

(1) (a) **Parts:** Wooden Handle

(b) **Process:** It is used for cutting woods in softwood.

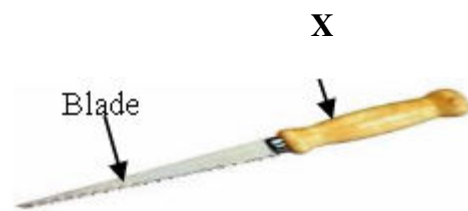

(2) (a) **Parts:** _____

(b) **Use:** _____

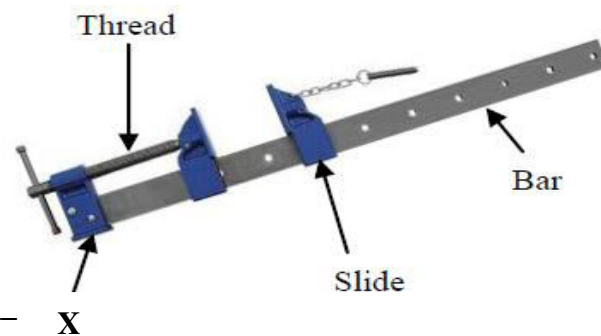

(3) (a) **Parts:** _____

(b) **Use:** _____

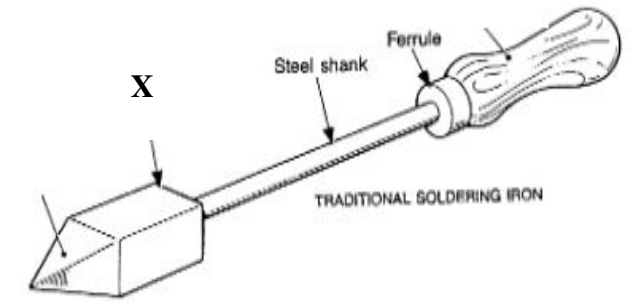

(4) (a) **Parts:** _____

(b) **Use:** _____

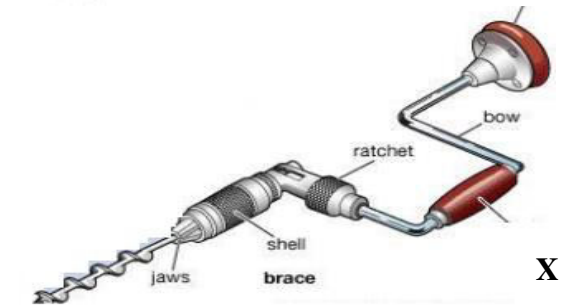

Name the **parts** labelled **A, B, C** given below and **state** the processes.
Use the **word list** given below.

WORD LIST:

Cooper Bit Wooden Handle Wooden block Teeth Working Face Parent Metal

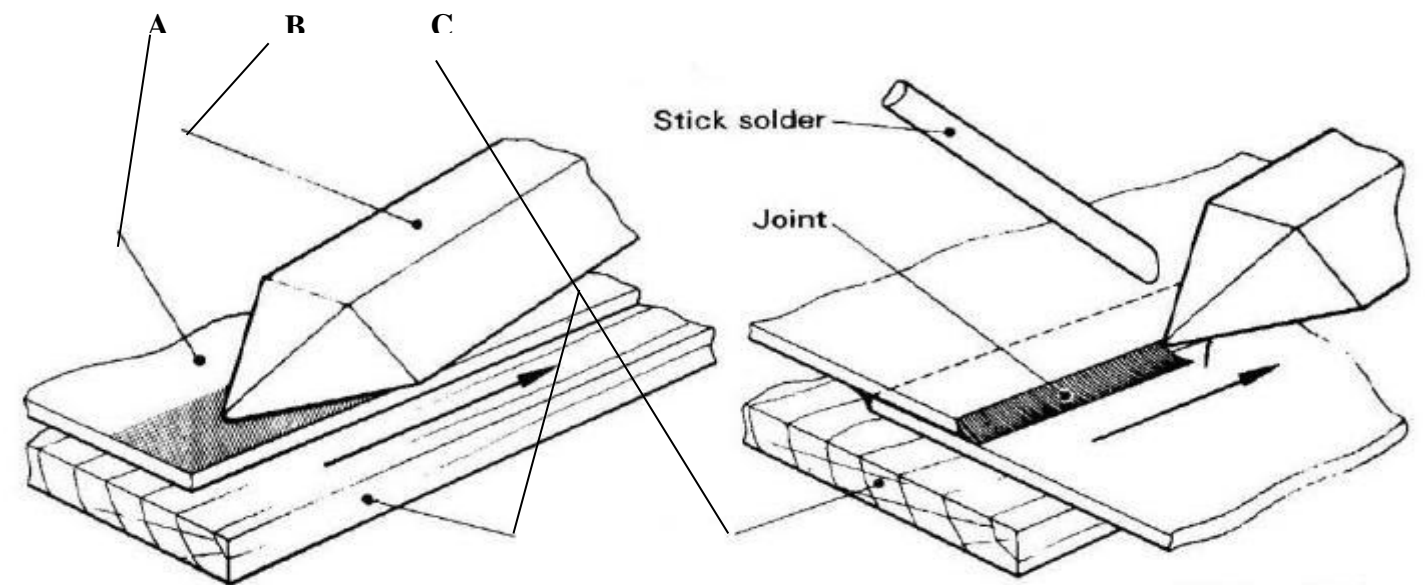

A. _____ B. _____ C. _____
(3 marks)

Process:

(1 mark)

The Pictorial diagram given below shows a **kitchen table**.
 Use the information provided in the diagram and your knowledge to answer the questions that follow.

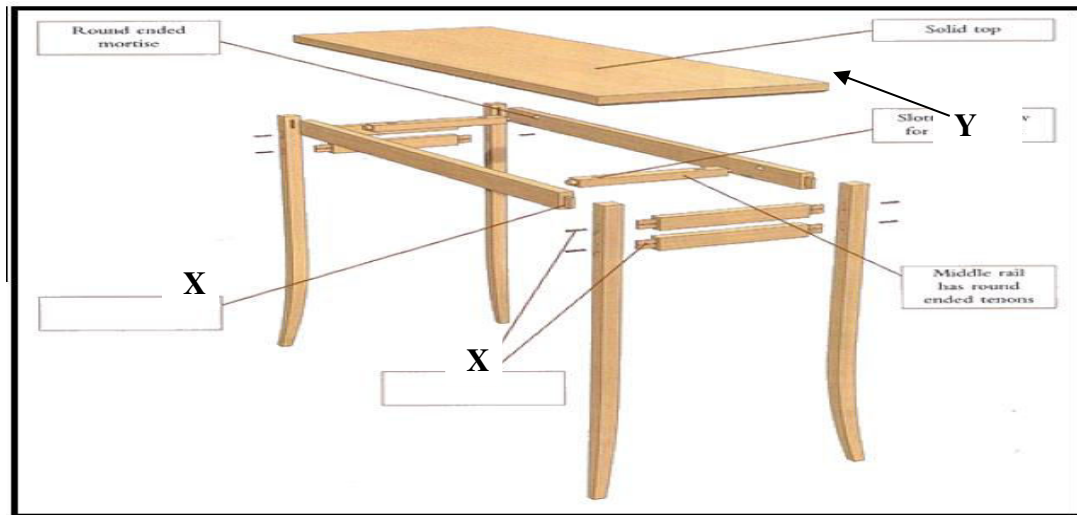

(1) Name a **suitable joint** that can **replace 'X'** and draw a neat **pencil rendered free hand pictorial sketch** of the joint to show the **grain** of the timber.

Name: _____

(2) State the first three steps in preparing the joint marked 'X'.

Step 1 _____

Step 2 _____

Step 3 _____

(1) **Name** the process in the diagram given below.



(2) Briefly **explain** the **steps** one should follow while put into practice the process?

3. State **one safety precautions** that must be followed while put into practice the process above.

Safety precautions: _____

THE END