

SHEET 1

PENANG SANGAM HIGH SCHOOL

P. O. BOX 44, RAKIRAKI

LESSON NOTES - 26

SCHOOL: PENANG SANGAM HIGH

SUBJECT: TECHNICAL DRAWING

YEAR/ LEVEL: 11 C/D

Strand	TD11.1. GEOMETRY
Sub - Strand	TD11.1.4 SOLID GEOMETRY & SURFACE DEVELOPMENT
Content Learning Outcome	TD11.1.4.1 Draw the auxiliary views of truncated solids and identify and develop skills in constructing developments of interpenetration of prisms and cylinders.

**SOLID GEOMETRY AND SURFACE DEVELOPMENT**

- Continued from Worksheet 25

**Given:** The plan and elevation of a truncated Cylinder.

**Required:** Draw the true shape and half development of the truncated Cylinder.

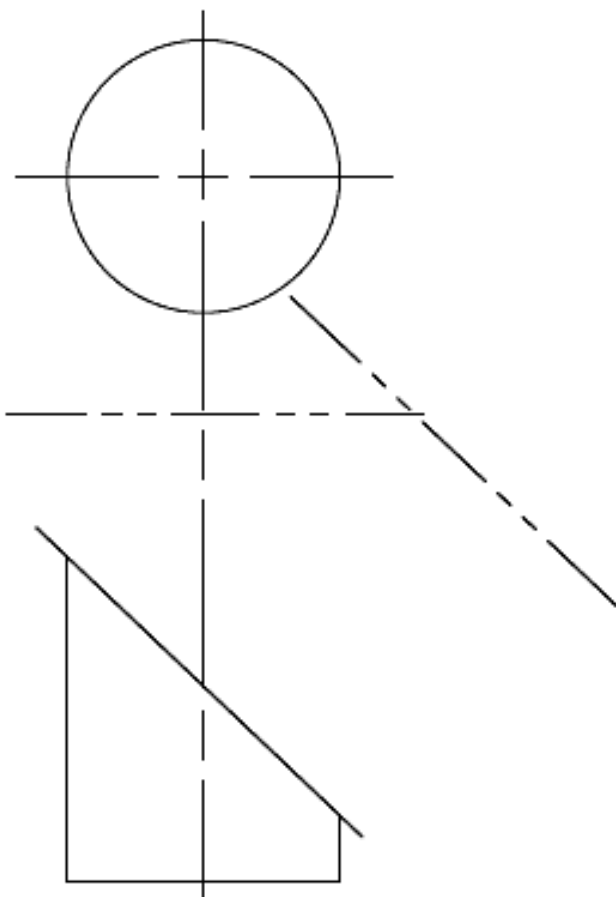

**Given:** The plan and elevation of a truncated triangular pyramid.

**Required:** Complete the elevation and the sectional plan.

Draw the development of the frustrum.

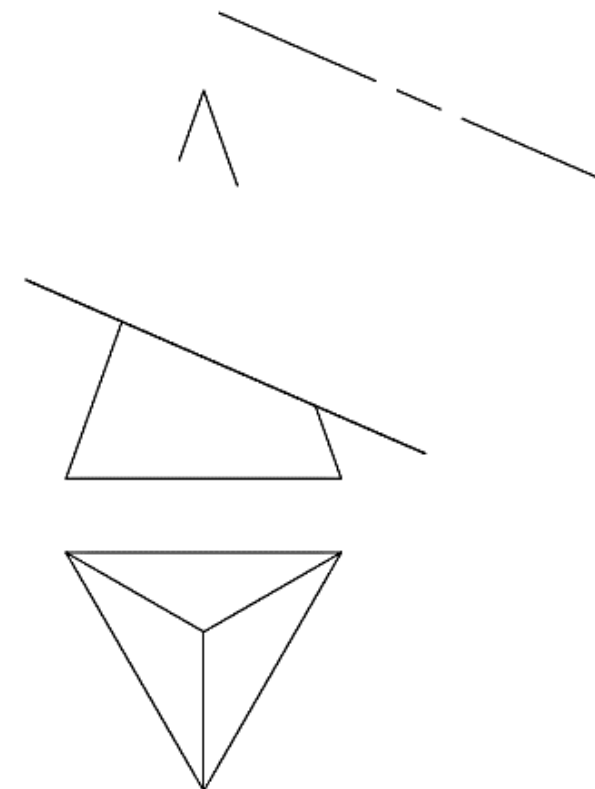

**Given:** The plan and elevation of a truncated Cone.  
**Required:** Complete the sectional plan and the true shape  
Draw the development.

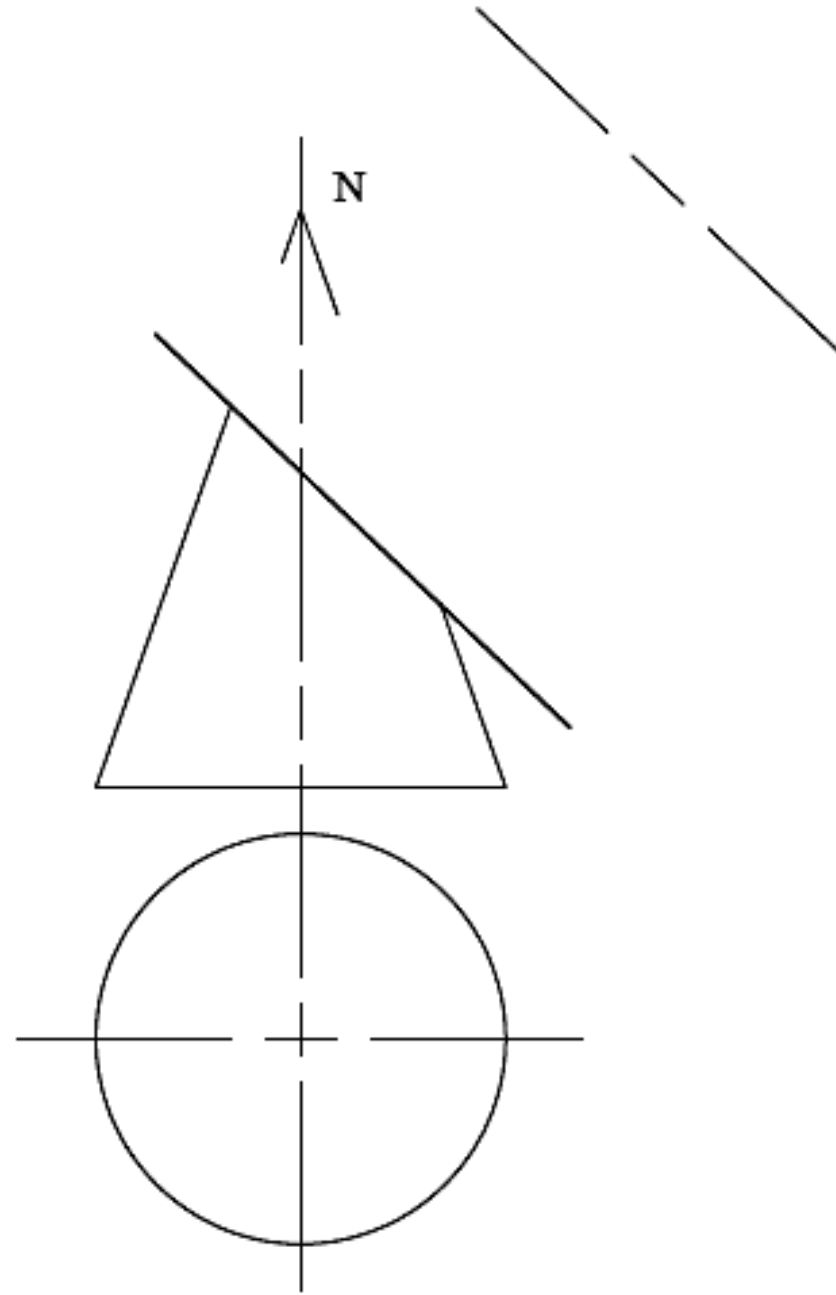

+ N